

VOLTDEER

Powered by  PYLONTECH

AC COUPLED SERIES

SR5000 Pro-2500

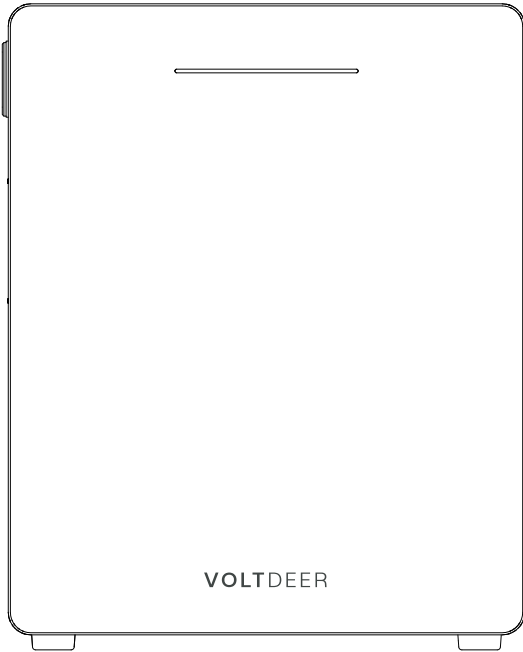

User Manual

Legal Notice

©2025 Shanghai Voltdeer Technology Co., Ltd. All rights reserved.

Without the prior written consent of Shanghai Voltdeer Technology Co., Ltd., it is prohibited to copy or distribute this manual or any part thereof in any manner, or upload this manual to third-party platforms such as public networks in any way.

Disclaimer

This manual is intended to guide the installation, use and maintenance of this product. Before using this product, please read this manual completely and keep it properly. The pictures, diagrams, interfaces and parameters herein are for illustrative purposes only. Please refer to the actual product and official announcements for specific details. Shanghai Voltdeer Technology Co., Ltd. (hereinafter referred to as "the Company") reserves the right to update or modify the manual content, product specifications and functions without prior notice.

Failure to install and use in accordance with this manual or applicable laws and regulations may result in personal injury, property damage or warranty invalidation. The relevant risks and consequences shall be borne by the user. Please only use accessories, consumables and services approved by the Company. Do not modify or disassemble the product without authorization.

Shanghai Voltdeer Technology Co., Ltd. makes no express or implied representations or warranties regarding all information in this manual.

If any clause of this manual conflicts with applicable laws and regulations, the laws and regulations shall prevail. Such conflict shall not affect the validity and enforceability of the remaining clauses. Some disclaimer clauses may not apply in certain countries and regions, and in such cases, the relevant clauses shall apply to the maximum extent permitted by local laws and regulations.

The final interpretation right of this manual belongs to Shanghai Voltdeer Technology Co., Ltd.

Safety Precautions



Warning

1. Read this document and other relevant product documents before operation.
2. The installation of this product must comply with all applicable local laws, regulations or standards.
3. An overcurrent circuit breaker must be installed between this product and the power grid.
4. During installation and maintenance, use insulated tools and wear personal protective equipment.
5. Install this product in a clean, dry and well-ventilated environment.
6. Place this product out of the reach of children and pets. If the product is used near children, it must be under close supervision.
7. Before making any electrical connections, ensure that all loads (such as equipment powered by this product) are disconnected from the power supply.
8. When disconnecting the product, pull the plug instead of the power cord to reduce the risk of damage to the plug and cable.
9. Do not insert fingers or hands into the product.
10. Do not expose this product directly to sunlight, rain or snow.
11. Do not expose this product to strong electromagnetic fields to prevent radio interference.
12. Do not install or operate this product near sources of flammable, explosive, corrosive or corrosive substances.
13. Do not install or operate this product under extreme weather conditions such as lightning, heavy rain or strong winds.
14. Do not subject this product to severe impact, vibration or dropping to avoid physical damage.
15. Do not drag, squeeze, step on this product or throw it into fire, otherwise there is a risk of explosion.
16. Do not use damaged wires or cables for this product.
17. Do not damage, deface or remove any identification labels on this product.
18. Do not disassemble, repair or modify this product by yourself. For any maintenance or repair services, please contact Voltdeer customer service.
19. Do not place this equipment near open flames, heat sources or flammable materials.
20. Do not shake this equipment.

Safety Precautions

21. Do not use the equipment if the outer casing is severely damaged.
22. Do not place the battery in high temperature or low pressure environments, as this may cause danger.
23. Do not disassemble or damage the battery. The released electrolyte is toxic and harmful to the skin and eyes.
24. Do not use any unofficial or unrecommended components and accessories. For replacements, please contact Voltdeer customer service for further assistance.
25. Do not clean this product with flammable or toxic solvents. Use a dry soft cloth for wiping.
26. Do not place heavy objects (> 40kg) on this product.
27. Equipment disassembly: For safe disassembly of this product, please perform the following steps in sequence:
 - a. Turn off the electrical equipment connected to the AC outlet of this device.
 - b. Unplug the power cord from the AC outlet of this device.
 - c. Turn off the power to this device.
 - d. Disconnect the grid connection cable of this device.
28. Grounding instructions: This product must be grounded. In case of failure or breakdown, grounding provides a path with minimal resistance for current to reduce the risk of electric shock.
 - a. For your safety, the grid-connected wiring harness standard-equipped by Voltdeer contains a ground wire inside. The user must ensure that the ground wire of the wall socket is connected to the earth, and the plug must be correctly installed in a grounded socket in accordance with local specifications.
 - b. The plug must be correctly installed in a grounded socket in compliance with all local codes and regulations.
 - c. Improper connection of the equipment's grounding conductor may pose an electric shock hazard.
 - d. In the following cases, consult a qualified electrician and do not replace the plug provided with the product at will:
 - Uncertain whether the product is correctly grounded;
 - You find that the plug provided with the product does not match the socket.
29. External grounding instructions: If the wall socket has no ground wire, the product's grounding screw must be connected to the earth.

In installation locations with insufficient grounding or special grounding requirements specified by local regulations, supplementary grounding may be required. In such

Safety Precautions







cases, use the product's grounding terminal to establish a good ground connection.

30. Personnel requirements: Certain installation or maintenance tasks must be performed exclusively by qualified technical personnel. Refer to the personnel requirements emphasized in the product documentation to ensure these tasks are completed correctly and safely.

Safety Precautions



Usage

Symbol	Description	
	User Manual	Before installation, operation and maintenance, please carefully read the user manual and all safety instructions.
	Warning!	Disconnect the equipment from all voltage sources before maintenance.
	Warning! Electric shock hazard (maintenance)	There are no user-serviceable parts inside. Please entrust maintenance to qualified personnel.
	Warning! Burn hazard	Do not touch the casing during equipment operation.
	Warning! Electric shock risk	Wait at least 5 minutes after all power supplies are disconnected before performing maintenance.
	CE marking	The equipment meets the basic requirements of EU regulations.
	Waste Electrical and Electronic Equipment (WEEE) Directive	Do not dispose of this equipment as household waste. Please comply with local requirements for the disposal of electronic waste.

1. This device is not recommended for powering personal medical devices.
2. Ensure good ventilation when using the equipment.
3. Do not move or invert the equipment during use. Place the equipment correctly.
4. Do not stack heavy objects on the equipment.
5. For safety, only use accessories (cables, etc.) provided or recommended by Voltdeer. Voltdeer is not responsible for damage caused by third-party equipment.
6. Battery maintenance shall be performed or supervised by personnel familiar with batteries.
7. The casing has an IP65 rating

Safety Precautions

Transportation

1. Do not carry the equipment on an airplane.

Maintenance

1. Charge the equipment once every 3 months. For long-term storage, maintain the power level between 40% and 70% before storage. If the equipment is completely discharged, charge it within 12 hours. Prolonged power outage may cause irreversible damage to the equipment.
2. If the equipment fails to operate normally, please contact the supplier or the nearest service center.
3. Do not disassemble the equipment for maintenance or repair by yourself.
4. Please dispose of used batteries in accordance with the laws or regulations of your country or region.
5. To maintain the long-term optimal performance of the equipment, it is recommended to perform the following inspections at least every quarter:
 - a. Ensure unobstructed air flow around the inverter and remove dirt and debris from the heat dissipation vents.
 - b. Inspect all exposed wires for insulation damage caused by sun exposure, friction with surrounding objects, aging and brittleness, or gnawing by insects and rodents. Repair or replace the wires if necessary.
 - c. Confirm that the indicator light display is consistent with the equipment operation status. Pay attention to all fault or error messages and take corrective actions if necessary.
6. Inspect all wiring terminals for signs of corrosion, insulation damage, high temperature or ablation/discoloration, and tighten the terminals.
7. Check the equipment for dust accumulation, insect nesting and corrosion. Clean as needed and regularly clean the protective screen.
8. If the surge arrester fails, replace the faulty surge arrester in a timely manner to prevent the inverter and other user equipment from being damaged by lightning strikes.

Note: Before performing any inspection or operation, ensure that the equipment is disconnected from all power connections. Wait 15 seconds after power-off to avoid electric shock risk.

The Company shall not be liable for damages caused by the following reasons:

Safety Precautions

- a. Damage caused by force majeure: equipment damage resulting from earthquakes, floods, volcanic eruptions, mudslides, lightning strikes, fires, wars, armed conflicts, typhoons, hurricanes, tornadoes, extreme weather conditions or other unforeseeable factors.
- b. Failure to operate in accordance with the usage conditions described in this manual.
- c. Installation and usage environment of the equipment not meeting relevant international, national or regional standards.
- d. Unauthorized personnel installing and using the equipment.
- e. Failure to follow the operation instructions and safety warnings in the product and related documents.
- f. Damage caused by unauthorized personnel disassembling and repairing the equipment.
- g. Damage to the equipment during transportation or handling.
- h. Damage caused by working temperature exceeding the specified working temperature range.
- i. The materials and tools you use do not meet the requirements of local laws and regulations and relevant standards.

Table of Contents

1 Packing List.....	1
2 Interface Description.....	1
3 Product Introduction	2
4 Operation Instructions	3
5 Indicator Light Description.....	3
6 Installation Instructions	4
7 Fault Codes and Corresponding Measures.....	9
8 Specifications List.....	12
9 APP.....	15
10 Frequently Asked Questions (FAQs).....	24

1 Packing List



SR5000 Pro

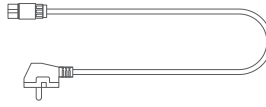

Grid-connected Power Cable

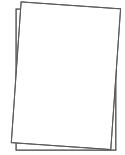

User Manual



Hanging Ear



Hanging Mount
(Optional)

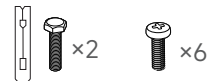

Expansion bolts

Screws

2 Interface Description

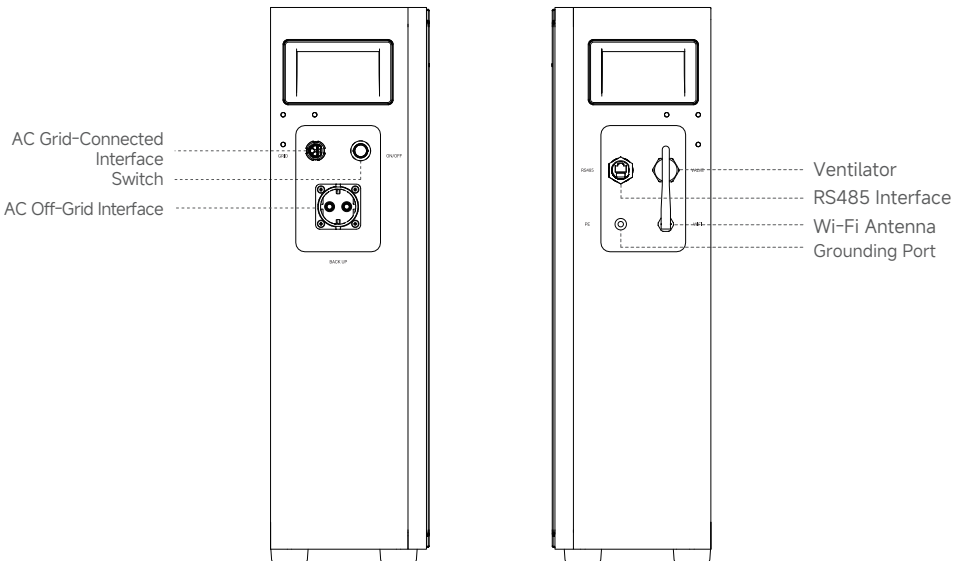

3 Product Introduction

The SR5000 Pro is an AC-coupled energy storage system with two working modes: AI automatic mode and manual mode. This system can charge at low peaks and feed power back at high peaks, thereby saving electricity for households while also providing a stable power supply.

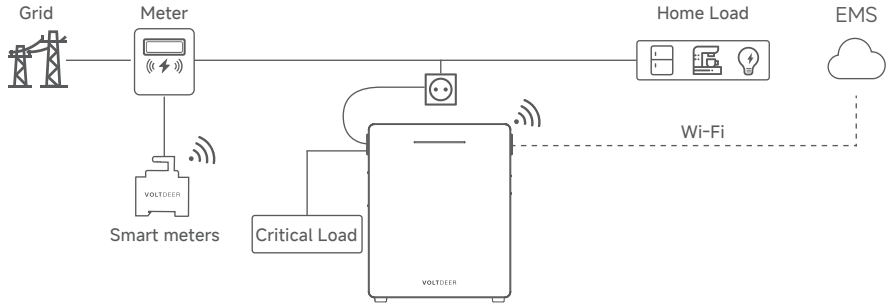

The SR5000 Pro product is compatible with all photovoltaic systems. Here are some home application scenarios when combined with solar energy systems.

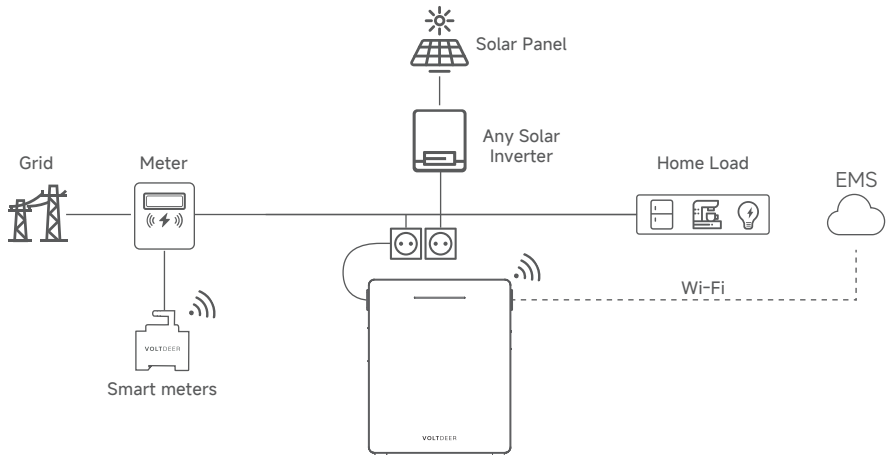

4 Operation Instructions

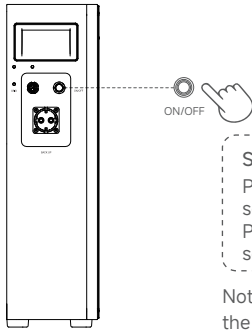

Switch:
 Power On: In the off state, press the switch button. After hearing the "click" sound, the green light on the button will light up, and the device will turn on;
 Power Off: In the on state, press the switch button. After hearing the "click" sound, the green light on the button will go out, and the device will turn off.

Note: After pressing the power-off button, wait at least 5 seconds before pressing the button again to turn on the equipment.

5 Indicator Light Description

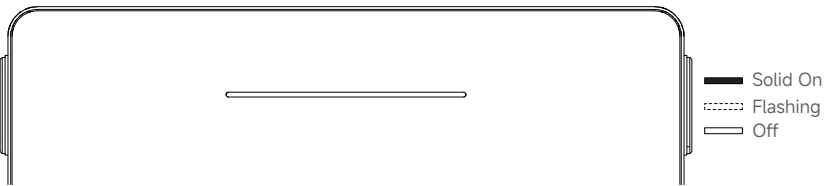

Color	Indicator Light	Settings Status	Description
Ice Blue		Charging, $0\% < SOC \leq 20\%$	Flashes once per second, continuously flashing
		Charging, $20 < SOC \leq 40\%$	Flashes once per second, continuously flashing
		Charging, $40\% < SOC \leq 60\%$	Flashes once per second, continuously flashing
		Charging, $60\% < SOC \leq 80\%$	Flashes once per second, continuously flashing
		Charging, $80\% < SOC \leq 100\%$	Flashes once per second, continuously flashing
		Fully Charged	
		Discharging, $SOC \leq 10\%$	Flashes once every 4 seconds, continuously flashing
		Discharging, $11\% < SOC \leq 20\%$	
		Discharging, $20 < SOC \leq 40\%$	
		Discharging, $40\% < SOC \leq 60\%$	
		Discharging, $60\% < SOC \leq 80\%$	
		Discharging, $80\% < SOC \leq 100\%$	
Red		Wi-Fi Network Successful	Flashes once per second, for a total of 3 flashes
		Device Malfunction	

6 Installation Instructions

6.1 Pre-installation Inspection

Before unpacking, please check the packaging for any obvious damage, such as holes, cracks, or other signs that may indicate internal damage. Verify the equipment model. If the packaging is abnormal or the equipment model does not match your purchase, do not open it and contact your dealer as soon as possible.

After unpacking, check that all accessories are complete and that the equipment surface is free of obvious damage. If any items are missing or damaged, contact your dealer.

6.2 Selecting an Installation Location













Installation angle requirements: This equipment must not be installed tilted, flat, upside down, or on its side.

Selection of Installation Location: Please select a sturdy brick or concrete structure, concrete wall, or floor. If other types of walls and floors are chosen, they must be made of flame-retardant materials and meet the load-bearing requirements of the equipment.

When installing this device, ensure that there are no other devices or flammable or explosive materials around it, and leave enough space to meet the requirements for heat dissipation and safety isolation.

6.3 Installation Tools

Installation tools include, but are not limited to, the recommended tools listed in the table below. During on-site installation, other auxiliary tools may be used as needed.

Screwdriver		Multimeter	
Wrench		Tape measure	
Diagonal pliers		Cable ties	
Insulated gloves		Insulated shoes	
Utility knife		Goggles	
Wire stripper		Marker pen	

6 Installation Instructions

6.4 Installation Environment Requirements

To meet the requirements for heat dissipation and safety isolation, when installing this equipment, the top and sides of the equipment must be at least 150 millimeters away from the nearest obstacle.

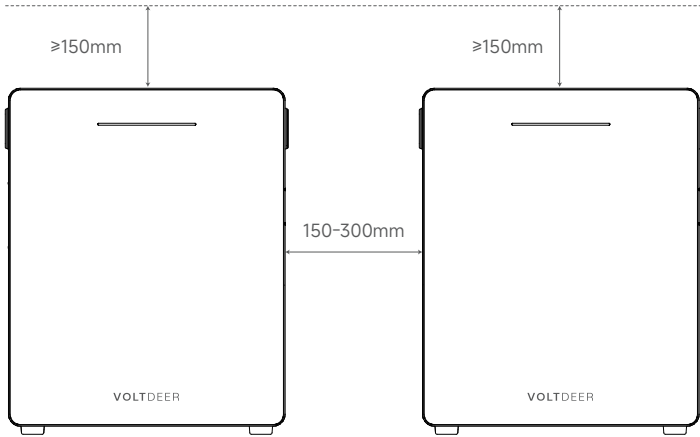

6.5 Fixing Method

Based on your needs, select a solution for this device and follow the steps shown in the diagram:

- ① Floor installation (anti-tipping fixation required): Use the included mounting brackets to securely fix this device to the wall.

6 Installation Instructions

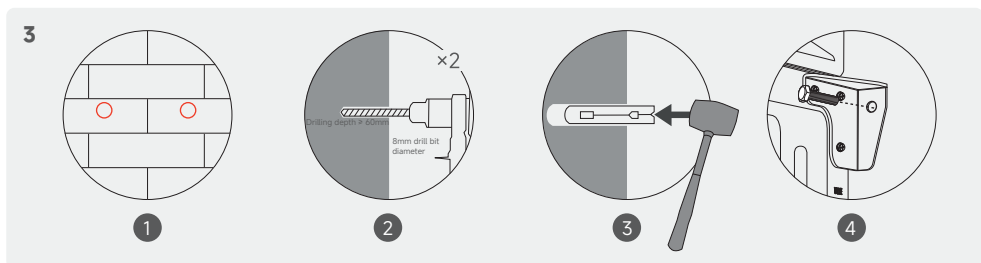
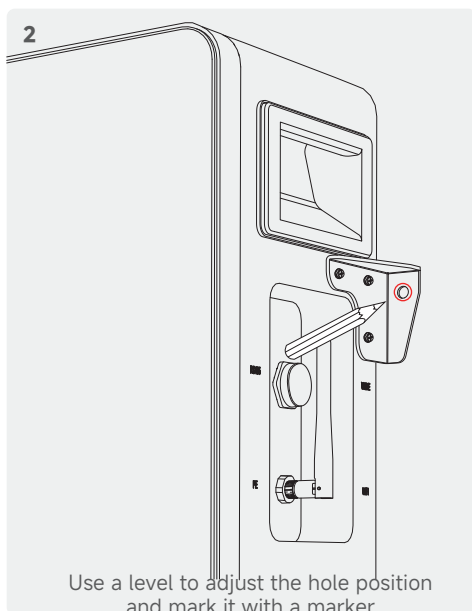
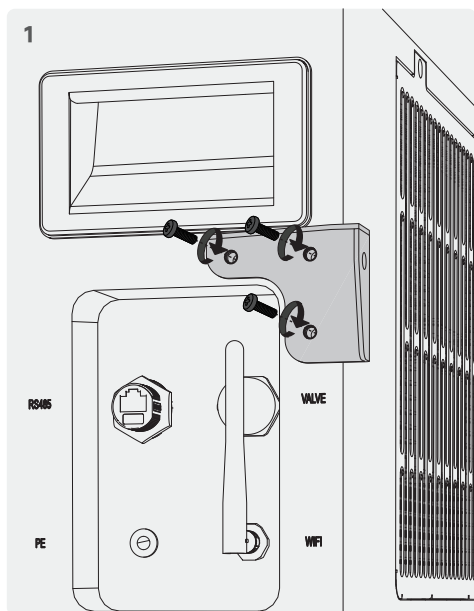

6 Installation Instructions

② Wall-mounted installation:

Use the included mounting ears and bracket (optional) to reliably wall-mount this product.

Note: Before drilling, please be sure to check the wall for water pipes and electrical wires to avoid potential safety hazards.

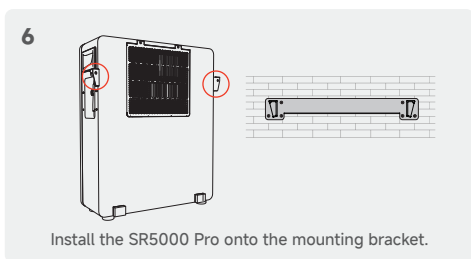
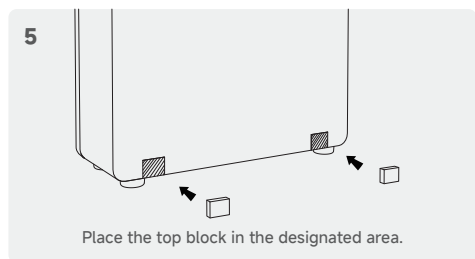
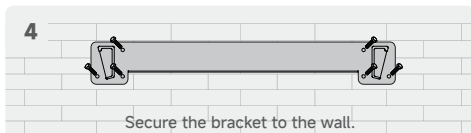
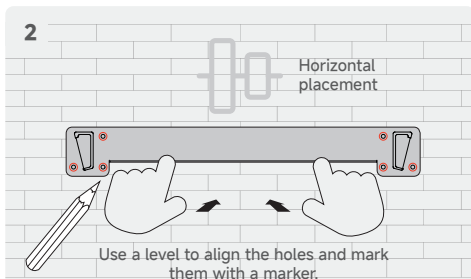
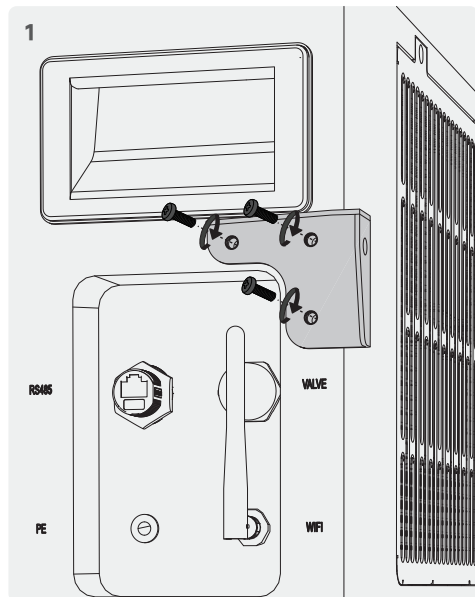

6 Installation Instructions

6.6 Grid Connection

- ① Connect the grid connection harness to the energy storage device, insert the AC power plug into the socket, and connect it to the local power grid.

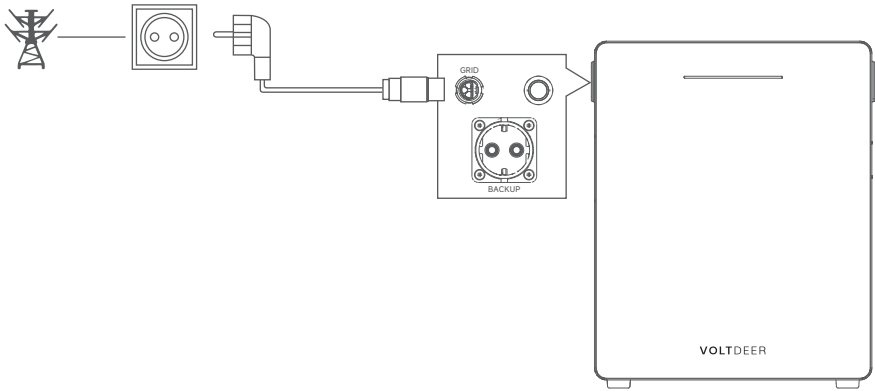

- ② Connecting critical loads/micro-inverters.

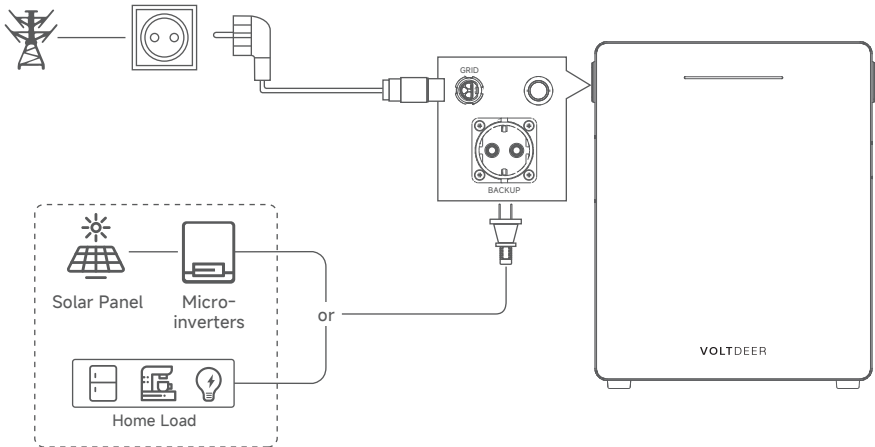

7 Fault Codes and Corresponding Measures

7.1 Fault Code

Fault code	Fault Name	Output Affected	Description
1	Low battery voltage alarm	Yes	Battery voltage is lower than the voltage alarm threshold. Battery discharge alarm is triggered, and output stops.
2	Battery EOD	Yes	Battery voltage is at low level. Battery discharge protection is activated, and output stops.
3	The average discharge current of the battery is too high protect	Yes	If the average discharge current of the battery is greater than the maximum input battery current for one minute, the output is turned off and the battery discharge protection stops.
4	Battery software overcurrent alarm	Yes	Current exceeds the software overcurrent alarm threshold. Battery overcurrent alarm is triggered, and output stops.
5	Battery open circuit	Yes	Mains is present, and the equipment is not turned on by pressing the button.
6	Battery overvoltage alarm	Yes	Battery voltage exceeds the set overvoltage threshold, and output stops.
7	Low battery capacity	No	Reminder for low battery capacity.
8	Low battery capacity shutdown	Yes	Battery capacity rate is low. Output stops, and the battery shuts down.
9	Bypass output overload	Yes	Mains bypass supplies power to the load. The load is overloaded, AC output is turned off, and mains charging stops.
10	Inverter output overload	Yes	The inverter is overloaded. AC output is turned off, and output stops.
11	Inverter AC output short circuit	Yes	Inverter AC output is short-circuited. AC output is turned off, and output stops.
12	Inverter hardware overcurrent alarm	Yes	Inverter AC output is overcurrent. AC output is turned off, and output stops.
13	Inverter DC component overload alarm	Yes	Abnormal regulation of the DC component of the inverter voltage. AC output is turned off, and output stops.
14	Bus software overvoltage	Yes	Internal battery boost. Software protection for bus voltage overvoltage is activated. AC output and charging are turned off.
15	Bus hardware overvoltage	Yes	Internal battery boost. Hardware protection for bus voltage overvoltage is activated. AC output and charging are turned off.
16	Bus undervoltage alarm	Yes	Internal battery boost. Bus voltage undervoltage protection is activated. AC output and charging are turned off.
17	Bus short circuit	Yes	Internal battery boost. Bus voltage short-circuit protection is activated. AC output and charging are turned off.
18	Inverter radiator over-temperature	Yes	The temperature of the radiator for AC charging or battery inverter discharge is too high. AC charging or battery inverter discharge is turned off.

7 Fault Codes and Corresponding Measures

19	Mains input relay short circuit	Yes	Short-circuit protection for the AC input relay to prevent reverse feeding of the inverter AC output to the bypass AC input.
20	Output relay short circuit	Yes	Short-circuit protection for the AC output relay. Inverter output and all charging functions are turned off.
21	Fan fault	Yes	Fan jamming or failure fault. Inverter output and charging are turned off.
22	BMS communication fault	Yes	Communication failure between the inverter and BMS. Inverter output and charging are turned off.
23	BMS abnormal alarm	Yes	Check the lithium battery BMS fault type and then clear the lithium battery fault.
24	BMS battery over-temperature	Yes	Cell temperature exceeds the BMS over-temperature threshold.
25	BMS battery overcurrent	Yes	Current exceeds the BMS overcurrent threshold.
26	BMS battery overvoltage	Yes	Cell voltage exceeds the BMS battery overvoltage threshold.
27	BMS battery undervoltage	Yes	Cell voltage is lower than the BMS battery undervoltage threshold.
28	BMS low battery temperature	Yes	Cell temperature is lower than the low-temperature threshold of the BMS.
29	Grid voltage overvoltage	Yes	Grid voltage exceeds the overvoltage threshold.
30	Grid voltage undervoltage	Yes	Grid voltage is lower than the undervoltage threshold.
31	Grid frequency over-frequency	Yes	Grid frequency exceeds the over-frequency threshold.
32	Grid frequency under-frequency	Yes	Grid frequency is lower than the under-frequency threshold.

7 Fault Codes and Corresponding Measures

7.2 Troubleshooting

Fault Code	Fault	Troubleshooting Measures
/	Indicator light not illuminating	Check if the battery switch is turned on.
/	APP data not updating	① Please close the app and log in again. ② Please check if the wireless connection between the device and your home network is normal. The network needs to be a 2.4G network. ③ Please remove the load, unplug the network cable, press the button to turn off the battery, press the button again to turn on after 10 seconds, and reconnect to the app.
1、2	Battery undervoltage	Charge the battery or restore it to above the undervoltage recovery voltage.
5	Battery open circuit	Check if the power-on button is activated.
6	Battery overvoltage	If the battery voltage exceeds the protection threshold, discharge the battery or reduce the voltage to below the overvoltage recovery point.
9、10	Bypass output overload / Inverter output overload	① Reduce the number of electrical devices; ② Restart the all-in-one machine to resume load output.
11	Inverter AC output short circuit	① Carefully inspect the load connection and eliminate the short-circuit fault point; ② Re-power the device to resume load output.
18	PV input overvoltage	Use a multimeter to check if the PV input voltage exceeds the maximum allowable input voltage.
21、22	Inverter radiator over-temperature / Transformer over-temperature	Allow the device to cool down to below the over-temperature recovery temperature, and normal charging /discharging control will resume.

Note: If you encounter a fault code not included in the table above, or if the fault persists after following the solutions in the table above, please contact our dealer or after-sales service department for technical support. Do not disassemble the device yourself.

8 Specifications List

Model	SR5000 Pro-2500
Battery Information	
Rated voltage	51.2V
Battery capacity	5120Wh
Cycle life	>6000 (25°C)
Cell type	LiFePO4
Depth of discharge (DOD)	90%
Capacity	100Ah
Mains Input	
Rated power	2.5kW
Grid connection type	L/N/PE
Rated grid voltage	230Vac
Grid voltage range	184-253Vac
Rated grid frequency	50Hz
Rated grid current	10.87A
Current harmonics	<3%
Grid-connected	
Rated power	0.8kW (Rated) / *2.5kW (Maximum)
Grid connection type	L/N/PE
Rated grid voltage	230Vac
Grid voltage range	184V-253Vac
Rated grid frequency	50Hz
Rated grid current	3.48A (Rated) / 10.87A (Maximum)
Power factor	>0.9
Current harmonics	<3%

8 Specifications List

Model	SR5000 Pro-2500
Off-grid Output	
Rated output power	2.5kW
Rated output current	10.87A
Rated output voltage	230Vac
Rated output frequency	50HZ
Voltage harmonics	<2%
General Parameters	
Class of equipment	Class I
Isolation type	Isolated
Charging temperature	0°C ~ +50°C
Discharging temperature	-20°C ~ +50°C
Relative humidity	0-95%
IP rating	IP65
Cooling method	Natural cooling
Altitude	2000m
Grid-connected standards	EN 50549-1/10、C10/11、VDE 4105
Regulations	IEC62477、IEC62619
Electromagnetic compatibility (EMC)	IEC/EN 61000
Other	RoHS、REACH、WEEE、UN38.3
Dimensions (L*W*H)	615*503*176mm
Weight	55±2kg
Grid connection	Single-phase plug
Display	LED indicator lights
Communication method	Wi-Fi & Bluetooth & RS-485

Note 1: The rated voltage/frequency range can be modified according to the requirements of the local power department.

*Enabling this function must comply with local regulations and be operated by professional technicians!

Note 2: Refer to local electrical regulations to determine the number of power sources that can be connected to each branch.

Note 3: The use of secondary lithium batteries and battery systems, especially misuse, may cause hazards and potential injuries.

Note 4: The product's maximum charging current is 60A, and the maximum discharging current is 60A; charging temperature range: 0°C-57°C, Discharging temperature range: -20°C-60°C; voltage range: 44.8V-58.4V. Use within the specified current, temperature, and voltage ranges to avoid injury.

8 Specifications List

Dimensions

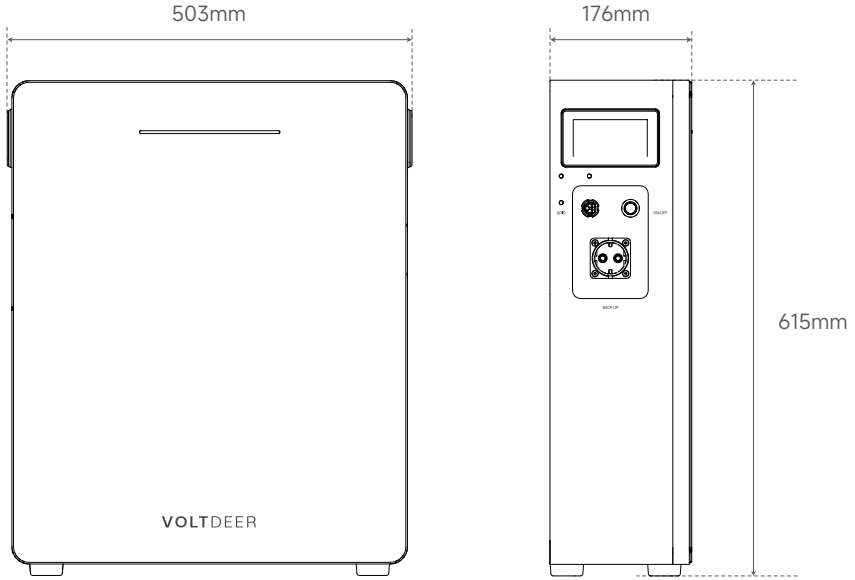

9.1 App Download

You can search for "AMBERROCK" in the mobile app store to download the app, or scan the QR code below for download.



9.2 Registration

For first-time use of the smart app, you need to register an account first.

If you already have an AMBERROCK app account, log in directly with your account and password.

Multi-language switching: The AMBERROCK app supports multiple languages, including Simplified Chinese, German, English, French, Dutch, and Italian. You can select and switch languages in the app as shown in the figure below. After logging in, you can also change the language at any time in the app's settings page.

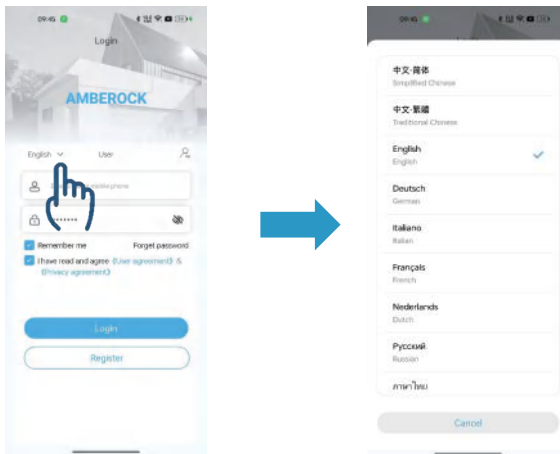

① Registration: Click the [Register] button to jump to the registration prompt. Fill in the required fields (marked with a red *) in the correct format to complete account registration.

Step 1: Access the registration page.

Click the " Register " button on the login page to enter the registration page.

9 APP

Step 2: Complete the registration process as prompted.

Enter your email address, input the correct email account as prompted, and verify it. The smart app supports email-based account registration.

After successful verification, check the checkbox in the agreement section to indicate that you agree to the "User agreement" and "Privacy agreement".

Step 3: Successful registration and login. After completing the account information, you will be redirected to the login page. Enter the newly registered account and password to log in.

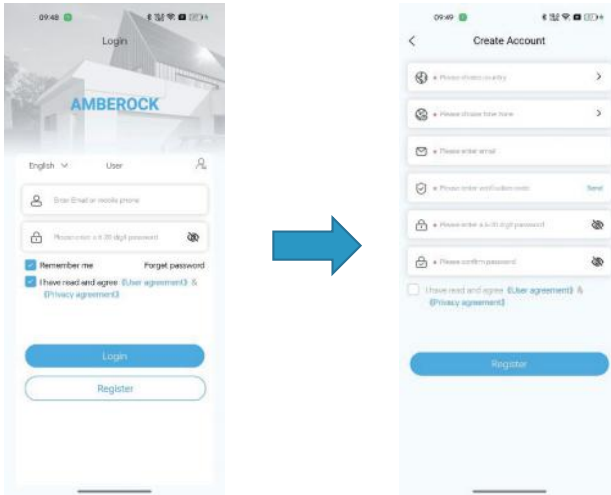

② Password retrieval: Click the [Forget password] button to jump to the password retrieval page. Select "Find email" and enter the required information as prompted.

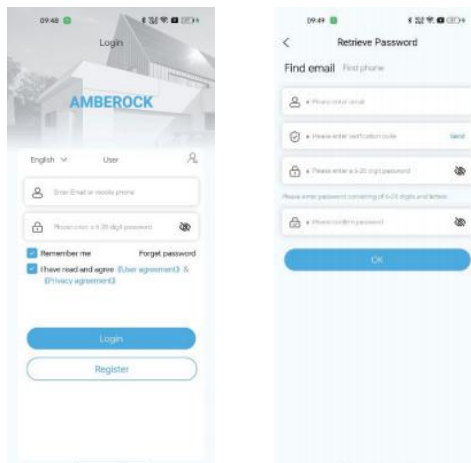

9.3 Login

After completing account registration, log in by entering your account and password, then click the [Login] button to access the app.

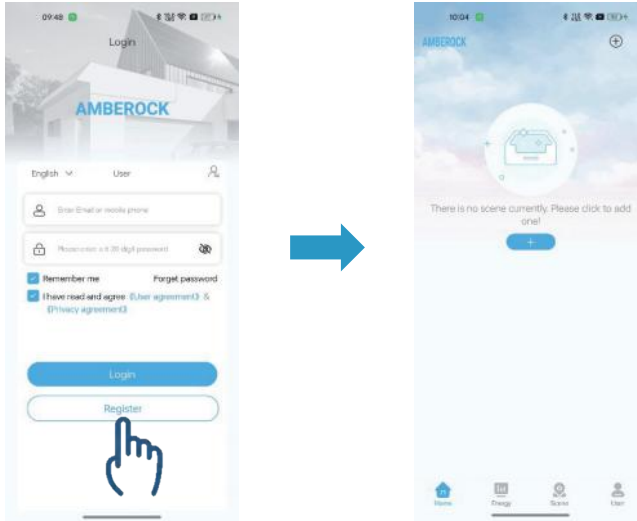

9.4 Add Scene

1. After entering the app for the first time, click the [+] button in the center of the screen to create your first scene; or click the [Devices] tab below and then click the [+] button in the upper right corner to add a scene.
2. Click the [+] button in the upper right corner to add a device, or click the [Devices] tab below to view and manage all devices.
3. Fill in the power station information as prompted and click "Save" to successfully add the power station.

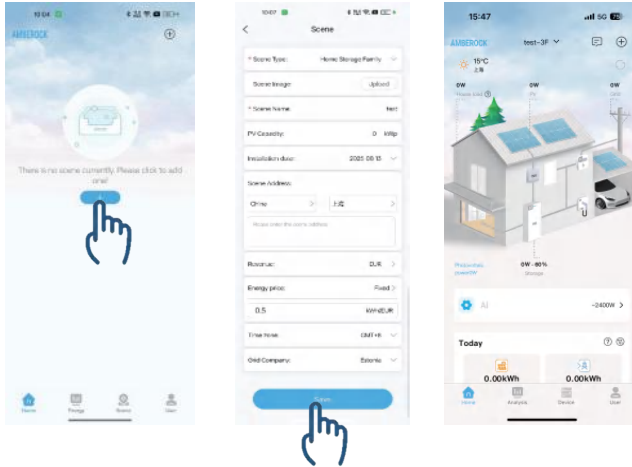

9.5 Add Device

9.5.1 Add Device And Connect to Wi-Fi Network

Power on the device and ensure it is functioning properly.

1. Select the scene where the device is located as the current scene.
2. Click the add button in the upper right corner of the "Family" page to enter the device addition page.
3. Add battery: Click the loaded serial number, scan the SN code of the meter reader module, or manually enter the serial number.
4. Add meter reader: Click the loaded serial number.

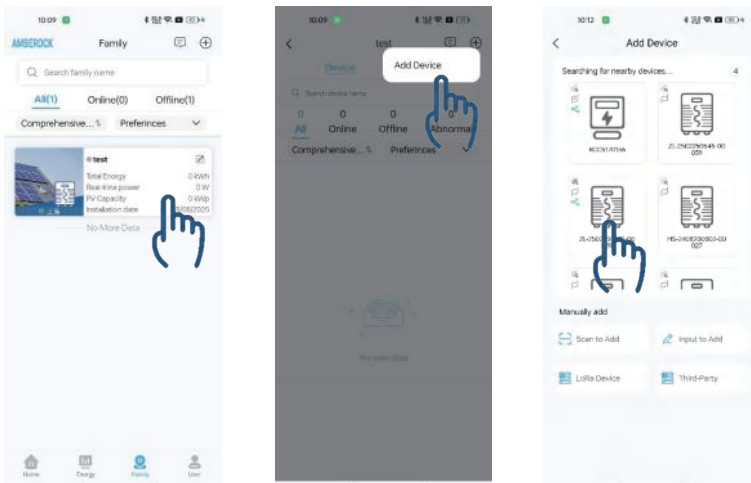

9.5.2 Network Mode Configuration

Ensure that the mobile phone's location and Bluetooth permissions are enabled. Then select or enter the Wi-Fi name and password to connect to the network. Click "NEXT" to proceed and wait for approximately 10 seconds for successful network configuration. If network configuration fails, check if the mobile phone's location and Bluetooth permissions are enabled, then follow the prompts again. Note: The smart meter reader and the device must be on the same local area network (LAN).

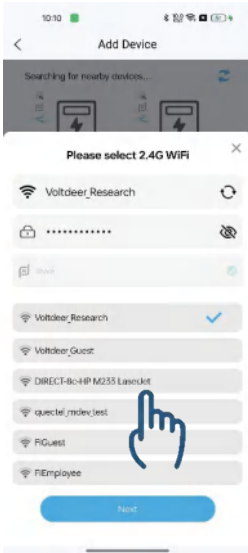

9.6 Check Collector Status

Return to the home page, click "Power Station" to enter the power station display page. Select the power station and click to enter the device viewing page. Click "Collector" to access the collector status page. Pull down to refresh the page. If the green "Online" indicator in the upper right corner of the collector is lit, the collector is in use. If it shows gray "Offline", the collector is not in use. Click the "Devices" page again and wait for two minutes. Pull down to refresh the page to display the list of power station devices.

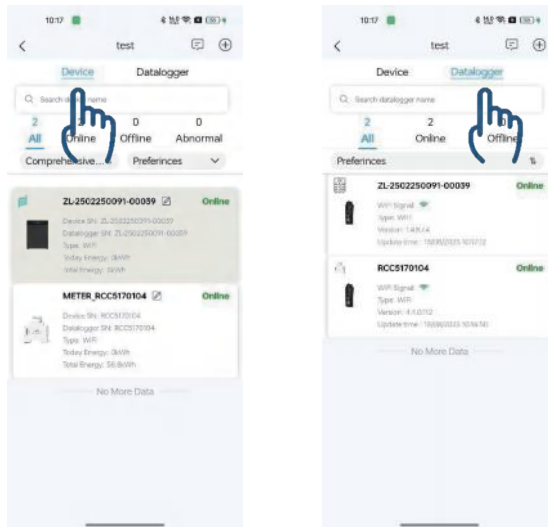

9.7 Data Browsing

9.7.1 Overview of Data Browsing

The app summarizes relevant monitoring and operation data of the associated power stations based on the login account type or linked business. It supports browsing of multiple power stations or a single power station. You can filter data by date to quickly view data charts and ranking systems, meeting your needs for overall monitoring and analysis of power stations.

9.7.2 Function Overview

Check today's energy output, status, total energy, total income, and installation date. Display the collection and summary of power station data, including "Power Station Status Announcement" and "Power Station Distribution" data. The "Power Station Status Announcement" classifies and filters the current status of each power station. The "Power Station Distribution" displays the location of power stations based on latitude and longitude for quick access to basic information and status.

9.8 Device Settings

9.8.1 Parameter Settings

To facilitate device management, you can set device parameters via the app.

Function description: Remote settings require the user to first add the device, which must be connected to the network and powered on (online status). Default parameters are pre-configured and do not require manual setting. Under compliance with local regulations, the "Grid-connected Output Power" can be set to a maximum of 2500W.

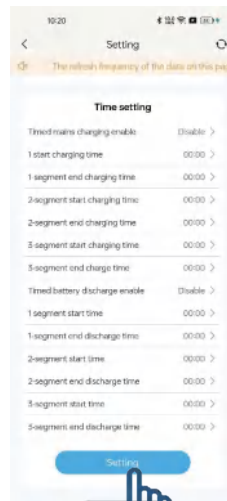
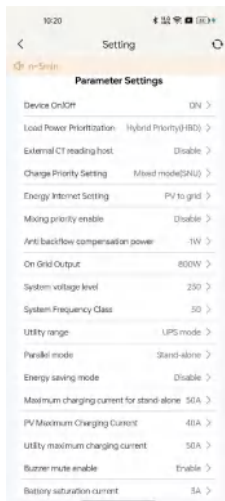
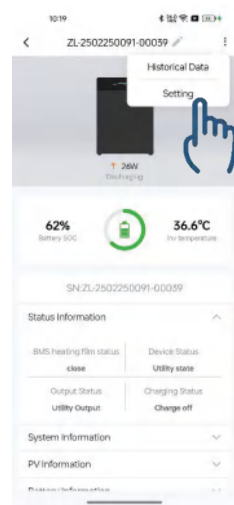

9.8.2 Zero Feed-in Setting

Select [Zero Feed-in] based on local grid policies and personal needs.

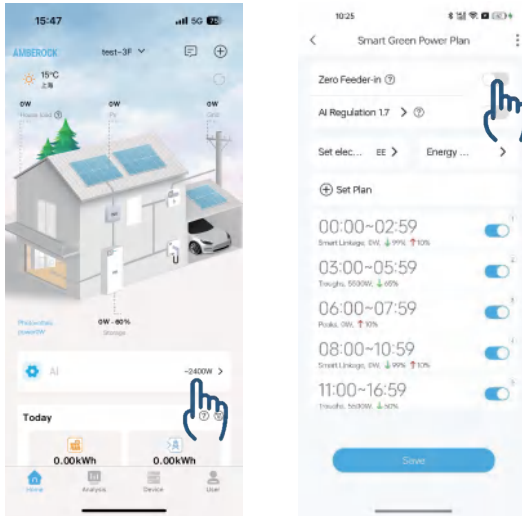

9.8.3 AI Regulation Setting

After setting the latest version of AI regulation, the app will automatically generate dynamic charging and discharging strategies based on local grid conditions, aiming to purchase electricity at low prices, discharge at high prices, and maximize photovoltaic utilization.

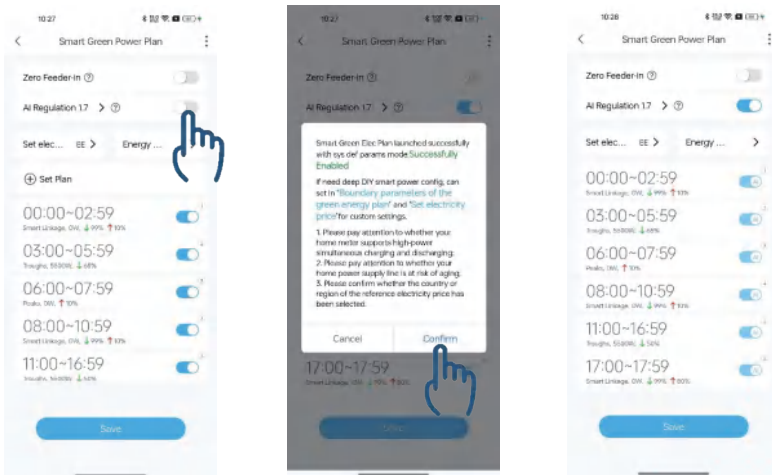

9.8.4 Electricity Price Setting

You can select the country and local grid company, set the wholesale price, and enter the tariff rate or VAT value. The app will calculate your income accordingly.

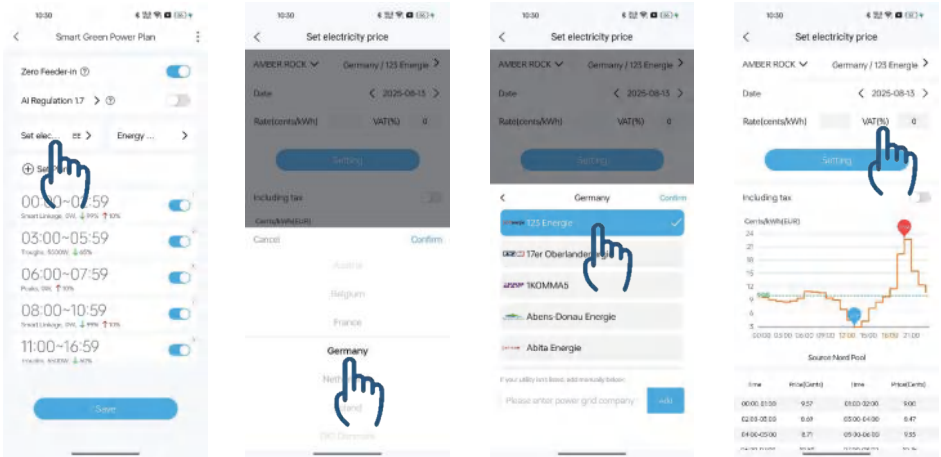

9.8.5 Custom Mode Setting

You can manually set charging and feed-in schedules.

Note: The default maximum feed-in power is 800W. If set to exceed 800W, it will still operate at 800W. Users can increase the maximum grid-connected power to 2500W in accordance with local regulations (see 9.8.1 Parameter Settings - [Grid-connected Output Power]).

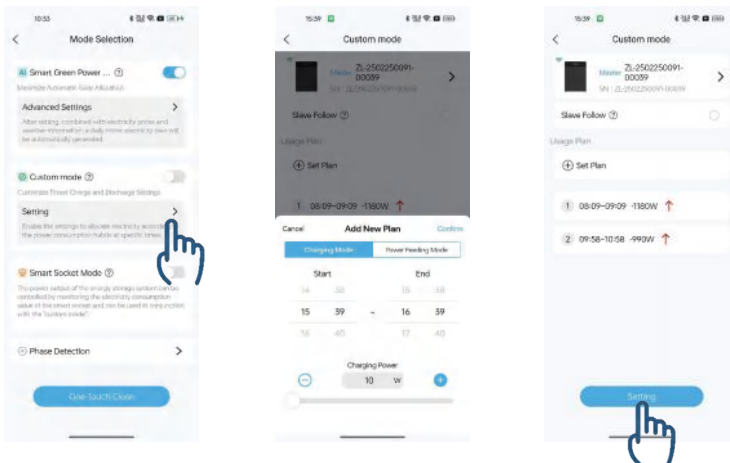

10 Frequently Asked Questions (FAQs)

1. What should I do if the AMBERROCK APP is not updating its data?

- ① Please close the app and log in again.
- ② Please check if the wireless connection between the device and your home network is normal.
- ③ Please remove the load, disconnect the network cable, press the button to turn off the battery, press the button again to turn it on after 10 seconds, and then reconnect to the app.

2. The AMBERROCK app cannot connect to the device. What should I do?

- ① Please ensure that the device barcode you entered matches the connected device.
- ② Please ensure that the network you are connecting to is compatible with 2.4G networks.
- ③ Frequent disconnections from the AMBERROCK APP may result in your router being blacklisted; you will need to restart your router.

3. How do I adjust the grid-connected power?

Please contact your dealer to obtain the parameter setting password. The grid-connected power must comply with local laws and regulations. Specific device steps: On the AMBERROCK APP homepage, click the battery icon to enter the battery settings interface. Then, click the three dots in the upper right corner to enter "Settings." In the "Parameter Configuration" option, select "Grid-connected Output Power," set the power, and enter the password to confirm.

4. What precautions should be taken when storing the device?

Before storing the device, turn it off and disconnect all connecting cables. Store it in a dry and well-ventilated environment. The storage temperature should be controlled between -5°C and 35°C, and the relative humidity between 0% and 60%. Avoid placing the device near fire sources, heat sources, water sources, or corrosive substances.

For long-term storage, maintain the battery power between 40% and 70%. After storage, it is recommended to inspect and charge the device every 3 months.

5. How to upgrade the device?

The device can be upgraded via the AMBERROCK app. Before upgrading, ensure the device has sufficient power and a stable network connection. Do not use the device or disconnect the network during the upgrade.

Voltdeer Warranty Card

User Information

Name: _____

Tel: _____

Email Add: _____

Postal Code: _____

Add: _____

Product Information

Model: _____

Serial Number: _____

Seller Information

Seller Name: _____

Tel: _____

Purchase Date: _____

Thank you for purchasing the Voltdeer product. Before use, please carefully read the user manual to understand the product precautions and usage methods. If the product malfunctions, please contact the local distributor or send an email to Service@amberock.com.cn.

For more information, please scan the QR code below to visit the Voltdeer official website.



 Shanghai Voltdeer Technology Co.,Ltd.
Building 8, Lane 739, Kangwei Road,
Kangqiao Town, Pudong New Area, Shanghai

 Service@amberock.com.cn
 www.voltdeer.com
 +86-21-50880510

Importer of this product: